



Z885

Supplied By:
**TRENCH DRAIN
SUPPLY**

877-903-7246
www.trenchdrainsupply.com

POLYETHYLENE OIL SEPARATOR

TAG _____

Dimensional Data (inches and [mm]) are Subject to Manufacturing Tolerances and Change Without Notice

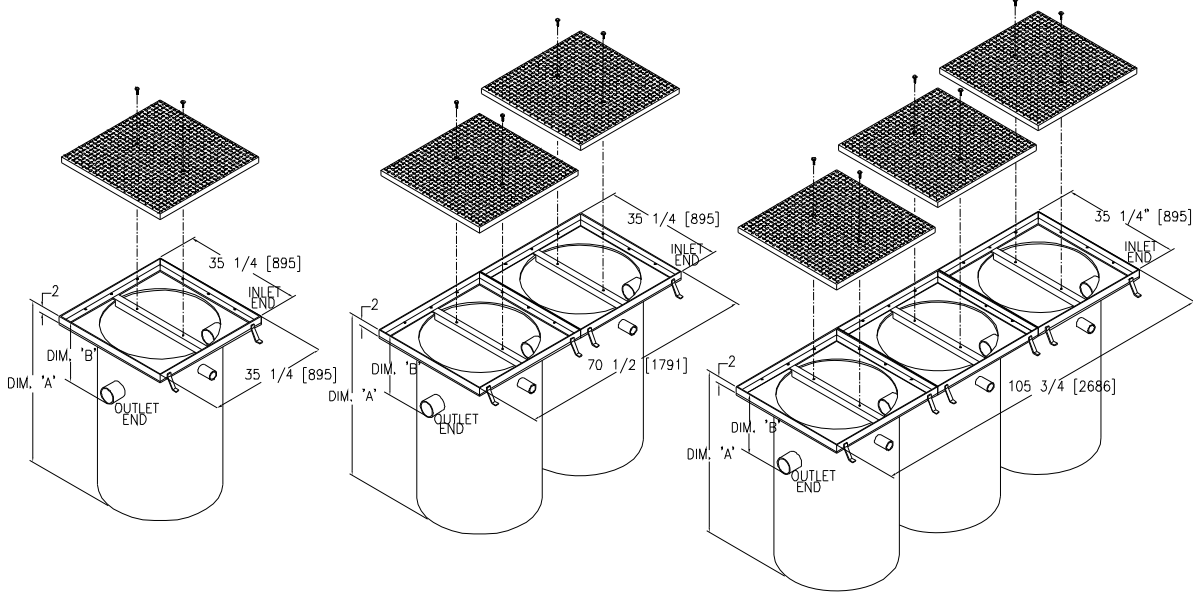

Z885-1 Single Basin
1-2 [51] Vent
_____ Invert

Z885-2 Double Basin
2-2 [51] Vents
_____ Invert

Z885-3 Triple Basin
3-2 [51] Vents
_____ Invert

_____ -Standard Cover

_____ -Heavy Duty Cover

ENGINEERING SPECIFICATION: Zurn Z885 Oil Separator-Polyethylene 1/4 [6] thick body, complete with Heavy-Duty Dura-Coated steel frame and 1/4 [6] thick steel diamond plate covers with medium duty top load classification. 4 [102] Dia. No-Hub inlet/outlet with 2 [51] Dia. No-Hub Vent connections. Dimensions shown nominally for reference. 18 [457] Trap seal standard. Invert dimensions are to bottom of pipe.

Single Basin Models

"A" Depth	B= Invert Dimension							Other
	8" [203]	10" [242]	12" [305]	14" [256]	16" [406]	18" [457]	20" [508]	
	(Gallons and [Liters])							
30" [762]	70 [265]	65 [246]	N/A	N/A	N/A	N/A	N/A	
36" [914]	100 [379]	93 [352]	84 [318]	78 [295]	72 [1829]	N/A	N/A	
48" [1219]	130 [492]	124 [469]	118 [447]	112 [424]	106 [2692]	100 [379]	94 [356]	
60" [1524]	150 [568]	143 [541]	138 [522]	132 [450]	128 [3251]	122 [462]	116 [439]	

Double Basin Models

"A" Depth	B= Invert Dimension							Other
	8" [203]	10" [242]	12" [305]	14" [256]	16" [406]	18" [457]	20" [508]	
	(Gallons and [Liters])							
30" [762]	140 [530]	130 [492]	N/A	N/A	N/A	N/A	N/A	
36" [914]	200 [757]	186 [704]	168 [636]	156 [590]	144 [545]	N/A	N/A	
48" [1219]	261 [988]	248 [939]	236 [893]	224 [848]	212 [803]	200 [757]	187 [708]	
60" [1524]	300 [1136]	286 [1083]	276 [1045]	264 [999]	256 [969]	244 [924]	232 [878]	

Triple Basin Models

"A" Depth	B= Invert Dimension							Other
	8" [203]	10" [242]	12" [305]	14" [256]	16" [406]	18" [457]	20" [508]	
	(Gallons and [Liters])							
30" [762]	210 [795]	195 [738]	N/A	N/A	N/A	N/A	N/A	
36" [914]	300 [1136]	279 [1056]	252 [954]	234 [886]	216 [818]	N/A	N/A	
48" [1219]	391 [1480]	373 [1412]	354 [1340]	336 [1272]	318 [1204]	299 [1132]	281 [1063]	
60" [1524]	450 [1703]	429 [1624]	414 [1567]	396 [1499]	384 [1454]	366 [1385]	348 [1317]	

*REGULARLY FURNISHED UNLESS OTHERWISE SPECIFIED
*CUSTOM SIZES AVAILABLE. CONTACT FACTORY FOR PRICES AND AVAILABILITY.

REV. C DATE: 1/27/11 C.N. NO. 120812
DWG. NO. 64267 PRODUCT NO. Z885